

e.cam Signature Series
All About Quality, Speed and Comfort

e.cam Signature Series



HD High Performance Detectors



syngo MI Workplace



Flash 3D



e.media patient comfort and education system

The e.cam® Signature Series has earned an enviable reputation for outstanding image quality and clinical flexibility. Siemens sets the standard of excellence with outstanding performance, styling and options.

e.cam Signature Series improves your clinical performance and the patient's experience every step of the way.

- The Signature Series features subdued color accents, creating a more open and calm environment.
- HD detectors with high count rate and energy independent performance ensure outstanding image quality.
- Our exclusive e.media option is the first-ever patient comfort and clinical education system, providing on-board interactive multimedia capability.
- Flash 3D, the most advanced SPECT iterative reconstruction technology available lets you optimize acquisition time and image quality.
- User-defined workflows improve department efficiency and throughput.
- syngo MI Workplace offers increased speed, capacity, and performance.
- Broad DICOM connectivity allows viewing of multimodality images side-by-side with nuclear medicine images.

signature series

Models



e.cam Variable Angle

e.cam Dual-Detector Variable-Angle
Allows for 180°, 90° and 76° detector configurations to optimize image quality for whole body, cardiac and general SPECT studies and high throughput for every acquisition type. The gantry, with its motion flexibility including caudal/cephalic detector tilt, offers full clinical utility for general purpose, cardiology, oncology, and neurology studies. The e.cam⁺ coincidence option is available for this camera.



e.cam Dual-Detector Fixed 180°
Optimized for both whole body and SPECT scanning with the detectors in opposing position, making it the ideal system for oncological applications. The open gantry permits easy access to both detectors for imaging of patients on gurneys and wheelchairs or in a standing position. The e.cam⁺ coincidence option is available for this camera.



e.cam Fixed 180°

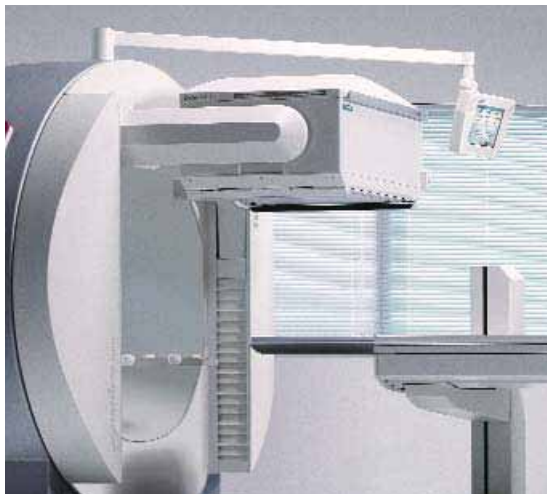

e.cam Single

e.cam Single
The e.cam single-detector system offers general purpose scanning flexibility with unrestricted access for gurneys and wheelchairs. This cost-effective system features a clinically versatile open gantry, caudal/cephalic detector tilt capability, automatic body contouring for SPECT and whole body scans, as well as upgrade paths to dual-head configurations.



e.cam Dual-Detector Multiangle Cardiac
Designed to meet the high-quality and high-throughput demands of cardiology practices. The optional Profile nonuniform cardiac attenuation correction accessory features a unique fixed multiple-line array that increases the accuracy of myocardial perfusion SPECT and enhances diagnostic confidence.



e.cam Multiangle Cardiac



e.cam™

e.cam Mobile
The mobile environment package* for e.cam allows installations in a wide range of coaches including trucks that do not require a commercial driver's license.

**available in the U.S. only.*



e.cam Single Standard
This system is an economical choice for general nuclear medicine applications. The single detector design allows patient imaging on gurneys and wheelchairs. Upgrade paths to additional e.cam features are available.



e.cam Single Standard

Features



HD High-Performance Detector

The state-of-the-art design provides increased performance, reliability, and serviceability.

e.media

The integrated DVD player and the redesigned Patient Positioning Monitor (PPM) combine to give e.media unlimited possibilities.

Collimators

e.cam offers a comprehensive selection of collimators for general and specialized applications. Siemens patented AUTOFORM assures high uniformity and precise angulation.

Patient Bed

The e.cam patient bed, featuring an ultrathin imaging pallet, is designed for ease of use, patient comfort, and image quality. Optional pallets add versatility.



Profile Attenuation Correction

The unique, multiple-line source array produces a profiled transmission source shape, effectively correcting myocardial perfusion SPECT studies for nonuniform attenuation from organs surrounding the heart.

Coincidence Acquisition

Ultrahigh efficiency HD detectors, special high count rate electronics, and axial shields to reduce scatter and random coincidence events combine to provide complete coincidence acquisition and processing functionality.





Detector 1

STAS

Detector 1

Detector 2

Detector 2

Workflow

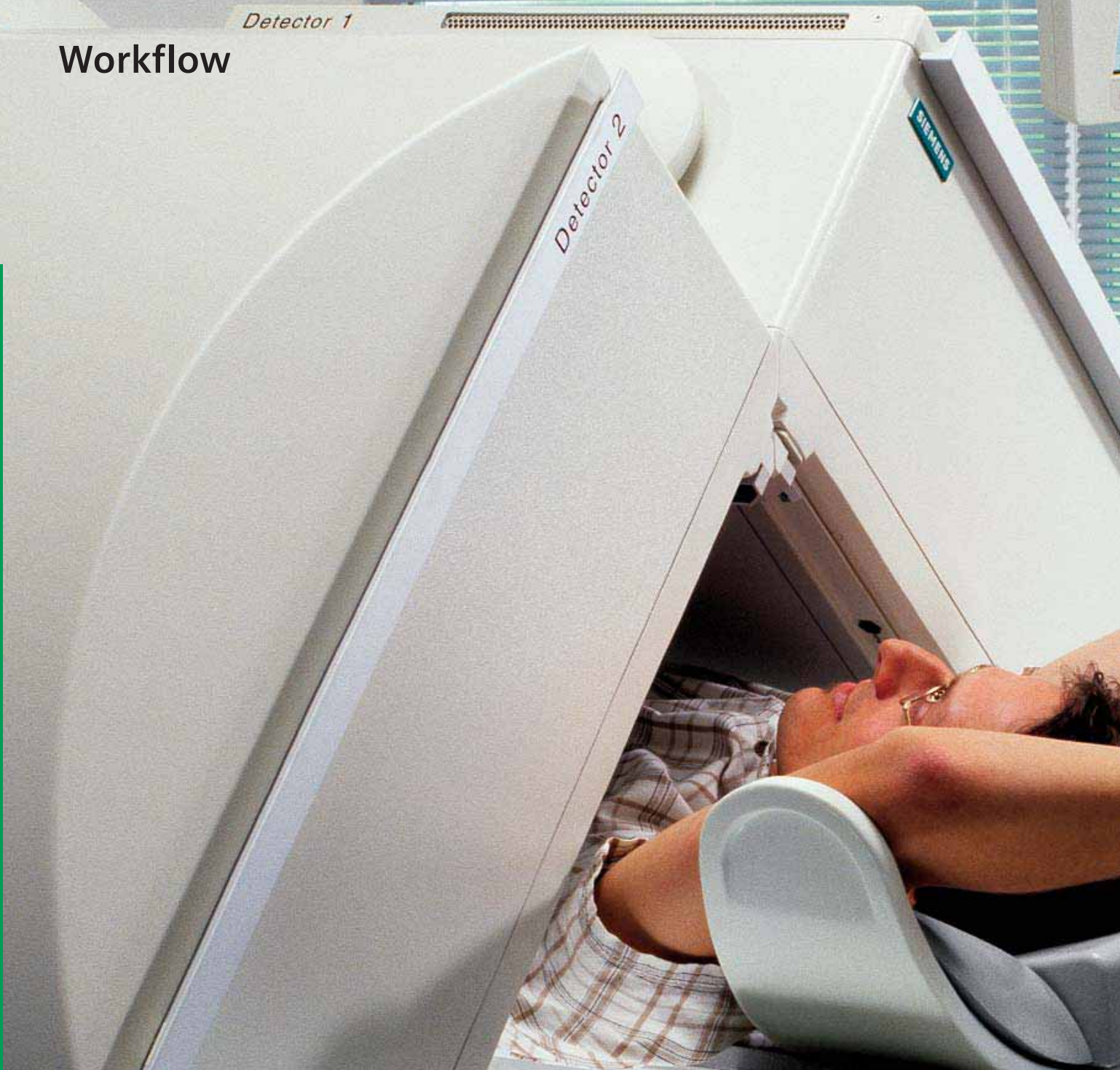

Patient Registration

When patients arrive in the Nuclear Medicine department to be scanned, the e.cam Signature Series system is already working for them. During patient registration, the necessary patient information is transferred to the syngo MI Workplace from the hospital's HIS/RIS system, eliminating a duplicate manual data entry step by the technologist.

Patient Preparation

With the patient data already in place, the technologist can proceed directly to patient orientation and positioning. With the touch of a button, the technologist can provide the patient a pleasant focal point during the scan — a multimedia system that can play CDs or DVDs, from a hospital infomercial to a cartoon to the latest Hollywood release.

Acquisition

Using the automatic contouring feature, the technologist significantly reduces patient setup time. As the patient rests comfortably on the patient handling table, the camera begins acquiring the required scans.



Processing

The *syngo* MI Workplace supports the entire clinical workflow by allowing the technologist to process and display images at one workstation. Optimized image quality is achieved by applying advanced reconstruction methods, such as *syngo* Flash 3D, scatter correction or *syngo* CT Attenuation Correction. The applications allow remarkable time savings and improve efficiency for the entire department.

Viewing

Having completed the patient scanning and processing procedures, the *syngo* MI Workplace automatically transfers the images to the physician for viewing and interpretation. The quality of the images, optimized by the high resolution flat-screen monitor, speaks for itself.

Data Management

After the physician completes reading and interpreting the data, the patient's results can be automatically forwarded throughout a wide-range of enterprise destinations — hardcopy printing, archiving, transfer to the referring physician — providing a flexible and intelligent manner of information management.

HD Digital Detector



The HD detector provides increased performance, reliability, and serviceability.

- Faster electronics increase count rate performance.
- Significant increase in reliability, resulting in maximum time between service calls.

	crystal thickness
Coincidence Specifications	5/8"
Maximum Singles Count Rate (per detector)	≥ 2.9 Mcps
Maximum NEC Count Rate (70 cm whole body phantom)	≥ 1.0 kcps
Scatter Fraction	≤ 14%
Reconstructed Resolution	
FWHM Central Axial	≤ 4.2 mm
FWHM Central Transaxial	≤ 4.8 mm
System Sensitivity	11 kcps/μCi/ml
300 kcps/Mbq/ml	300 kcps/Mbq/ml
Coincidence Timing Window	2t = 12 nsec

All values are determined at the manufacturer's facility, using the methods described in "NEMA Standards Publication for Performance Measurements of Scintillation Cameras."

Single photon values are determined at the manufacturer's facility using the methods described in NEMA Standards Publication NU 1-2001 "Performance Measurements of Scintillation Cameras". The specialized phantoms and software required to reproduce these measurements are available from Siemens.

Coincidence values are measured in accordance with NEMA Standards Publication NU 2-1994 using coincidence mode (photopeak-photopeak) at 511keV with the exception of Noise Equivalent Count Rate (NEC) which is measured using NEMA Standards Publications NU 2-2001.

	crystal thickness	
	3/8 "	5/8"
Primary Specifications		
Intrinsic Spatial Resolution		
FWHM in CFOV	≤ 3.8 mm	≤ 4.5 mm
FWHM in UFOV	≤ 3.9 mm	≤ 4.6 mm
FWTM in CFOV	≤ 7.5 mm	≤ 8.7 mm
FWTM in UFOV	≤ 7.7 mm	≤ 8.9 mm
Intrinsic Energy Resolution		
UFOV	≤ 9.9 %	≤ 9.9%
Intrinsic Flood Field Uniformity (uncorrected)		
Differential in CFOV	≤ 2.5%	≤ 2.5%
Differential in UFOV	≤ 2.7%	≤ 2.7%
Integral in CFOV	≤ 2.9%	≤ 2.9%
Integral in UFOV	≤ 3.7%	≤ 3.7%
System Spatial Resolution without Scatter with LEHR Collimator at 10 cm*		
FWHM in CFOV	7.4 mm	7.8 mm
FWTM in CFOV	14.1 mm	14.9 mm
Secondary Specifications		
Intrinsic Spatial Linearity		
Differential in CFOV	≤ 0.2 mm	≤ 0.2 mm
Differential in UFOV	≤ 0.2 mm	≤ 0.2 mm
Absolute in CFOV	≤ 0.4 mm	≤ 0.5 mm
Absolute in UFOV	≤ 0.7 mm	≤ 1.0 mm
Multiple Window Spatial Registration	≤ 0.6 mm	≤ 1.0 mm
Intrinsic Count Rate Performance in Air*		
Maximum Count Rate	310 kcps	310 kcps
Intrinsic Spatial Resolution @ 75 kcps		
FWHM in UFOV	≤ 4.1 mm	≤ 4.6 mm
FWTM in UFOV	≤ 7.8 mm	≤ 8.9 mm
Intrinsic Flood Field Uniformity @ 75 kcps (uncorrected)		
Differential in CFOV	≤ 2.5%	≤ 2.5%
Differential in UFOV	≤ 2.7%	≤ 2.7%
Integral in CFOV	≤ 2.9%	≤ 2.9%
Integral in UFOV	≤ 3.7%	≤ 3.7%
System Spatial Resolution with Scatter with LEHR Collimator at 10 cm*		
FWHM in CFOV	8.7 mm	8.9 mm
FWTM in CFOV	19.1 mm	19.5 mm
System Planar Sensitivity with LEHR Collimator at 10 cm*		
Absolute	202 cpm/μCi	225 cpm/μCi
System Planar Sensitivity with MELP Collimator at 10 cm (In 111)* (both energy windows at 20%)		
Absolute	430 cpm/μCi	565 cpm/μCi
Reconstructed Spatial Resolution with Scatter with LEHR Collimator		
Center	≤ 11.4 mm	≤ 11.5 mm
Radial	≤ 11.7 mm	≤ 12.0 mm
Tangential	≤ 8.4 mm	≤ 8.8 mm

* Typical Values

HD High-Definition Dynamic Digital Detector and Gantry Physical Specifications

Field-of-View (FOV)	53.3 x 38.7 cm (21 x 15.25 in.)
Diagonal FOV	63.5 cm (25 in.)

Crystal

Size	59.1 x 44.5 cm (23 x 17.4 in.)
Diagonal	69.2 cm (27 in.)
Thickness	9.5 mm (3/8 in.) or 15.9 mm (5/8 in.) or 25.4 mm (1 in.)

Photomultiplier Tubes

Total Number	59
Diameter	53-7.6 cm (3 in.) 6-5.1 cm (2 in.)
Type	bialkali high-efficiency box-type dynodes
Array	hexagonal

Shielding

Back	9.5 mm (0.375 in.)
Sides	12.7 mm (0.5 in.)
Min. and Max. in patient direction	27.9-36.4 mm (1.1-1.435 in.)

(For any point on the pallet at maximum 183 cm (6 ft.) from detector while the detector is at 25.4 cm (10 in.) radial position.)

Brain Reach

Distance from edge of detector housing to edge of FOV	7.6 cm (3 in.)
Height	193.0 cm (6 ft. 4 in.)
Width	167.6 cm (5 ft. 6 in.)
Depth	159.4 cm (5 ft. 2.75 in.)
Axis of Rotation (from Floor)	99.0 cm (3 ft. 3 in.)
Weight High-Energy Collimator	1755 kg (3900 lb.) Dual Det. 1170 kg (2600 lb.) Single Det.

Min. Patient Opening (HE Coll.)	9.0 cm (3.5 in.)
Min. Patient Opening (HR Coll.)	14.0 cm (5.5 in.)
Max. Patient Opening (HE Coll.)	62.0 cm (24.4 in.)
Max. Patient Opening (HR Coll.)	67.0 cm (26.4 in.)
Average Autocontour Distance	1.1 cm (0.45 in.)
Max. Radial Speed	120 cm/min. (47.2 in./min.)

Max. Lateral Position Left****	5.1 cm (2 in.)
Max. Lateral Position Right****	22.9 cm (9 in.)
Max. Lateral Speed	120 cm/min. (47.2 in./min.)

Single-Head, Dual-Head 180° and Dual-Head Variable-Angle (180°)

Max. CW Rotation Det. 1*	440°
Max. CCW Rotation Det. 1*	30°

Variable-Angle and Multiangle Cardiac (90°)

Max. CW Rotation Det. 1**	350°
Max. CCW Rotation Det. 1**	120°

Ring Rotation Range	470°
Rotational Accuracy	0.1°
Max. Rotational Speed	3 RPM
Min. Rotational Speed	0.33 RPM
Center of Rotation	≤ 0.25 pixel (64 x 64 matrix)
Max. Caudal Tilt (Outward)****	90°
Max. Cephalic Tilt (Inward)****	20°

Outer Room Positions*****

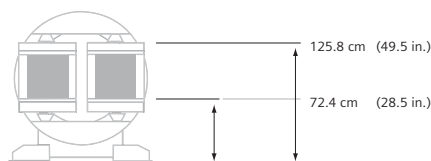
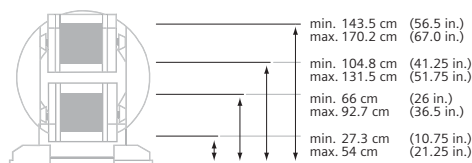

Electronics Enclosure

Height	105.4 cm (41.5 in.)
Width	55.9 cm (22 in.)
Depth	52.3 cm (20.25 in.)
Weight	99 kg (220 lb.)

System Environmental Requirements

Floor Loading Single-Head and Dual-Head	0.073 kg/sq. cm (150 lb/sq. ft.)
	200-240 Volt (±10%), 50-60 Hz
	3.0 kVA, 30 Amp
	single phase service
Heat Dissipation	7200K Joules/hr. (6800 BTU/hr.)
Temperature Range	15.5°-35°C (60°-95°F)
Max. Temperature Variance	4.4°C/hr. (8°F/hr.)
Humidity	15-80% noncondensing

* As seen from patient bed side, detectors at 180° opposed position, start with detector 1 on top.

** As seen from patient bed side, detectors at 90° cardiac position, start with detector 1 on top.

*** As seen from patient bed side. Gantry lateral motion for dual-head systems only.

**** Patient on patient bed with feet in gantry, with low-energy collimators.

***** Available with all collimators.

Patient Positioning Monitor



LCD Flat Panel Display — Patient Positioning Monitor

The e.cam system flat display panel is mounted on an arm extending from the top of the gantry. The display panel can be moved to any position for easy viewing by the technologist or patient. The display screens available on the display panel include: Persistence Mode, Gantry Mode, Persistence During Acquisition, and Gantry During Acquisition.

Flat panel display information includes:

- Rotation Angle
- Detector Radius
- Detector Tilt
- Elapsed Time
- View Number
- Count Rate
- Matrix Size
- Collimator Change
- Offset Zoom
- Time Remaining
- SPECT/Coincidence Mode
- Patient Bed Height
- Persistence Mode
- Gantry Lateral Position
- Patient Bed Position
- Patient Positioning Monitor
- Analyzer Energy Setting
- Window and Persistence
- 30.5 cm (12 in.) Adjustment Monitor Screen
- Profile Attenuation Source "On" Indicator



Optional e.media Patient Comfort and Education Package

e.media offers unlimited possibilities for patients and institutions. The integrated DVD plays high-quality video and sound through the Patient Positioning Monitor. The critical area where e.media can make an impact is in patient comfort. Relaxing or interesting video presentations can translate into less patient movement. Less patient movement means less repeat scans and better image quality. Less repeat scans and better image quality create a winning situation for everyone —patients, technologists, and physicians.

Examples of the material that can be displayed:

- Relaxation videos and music
- Entertainment for young patients
- Patient procedure information
- Audio CD
- Hospital promotional videos





Collimators



Versatile Design

e.cam provides a comprehensive selection of collimators for general and specialized applications. Siemens AUTOFORM assures high uniformity and precise angulation. The collimator exchange system is designed to allow even the heaviest collimators to glide quickly, easily and smoothly into place.

Collimators	LEHS Low Energy High Sensitivity ^{99m} Tc	LEAP Low Energy All Purpose ^{99m} Tc	LEHR Low Energy High Resolution ^{99m} Tc	LEUHR Low Energy Ultrahigh Resolution ^{99m} Tc	LEFB Low Energy Fanbeam ^{99m} Tc	ME Medium Energy ⁶⁷ Ga	HE High Energy ¹³¹ I	UHE Ultrahigh Energy ¹⁸ F
Isotope								
Hole Shape	Hex	Hex	Hex	Hex	Hex	Hex	Hex	Hex
Number of Holes (x 1,000)	28	90	148	146	64	14	8	4
Hole Length (mm)	24.05	24.1	24.05	35.8	35	40.64	50.8	50.5
Septal Thickness (mm)	0.36	0.20	0.16	0.13	0.16	1.14	2	3.4
Hole Diameter (mm across the flats)	2.54	1.45	1.11	1.16	1.53	2.94	3.4	2.5
Sensitivity @ 10 cm (cpm/μCi) ¹	1020	330	202	100	280	310	135	185
Geometric Resolution @ 10 cm (mm)	14.6	8.3	6.4	4.6	6.3	10.8	12.6	10.6
System Resolution @ 10 cm (mm) ¹	15.6	9.4	7.4	6.0	7.3	12.5	14.5	19.0
Septal Penetration (%)	1.5	1.9	1.5	0.8	1	1.2	3.5	3.4
Focal Length @ Exit Surface (mm)	n.a.	n.a.	n.a.	n.a.	445	n.a.	n.a.	n.a.
Weight in lb.	42	49	45	56	67	136	245	260
Weight in kg	18.9	22.1	20.4	25.2	30.5	61.8	111.1	117.0

1. Values measured in accordance with NEMA Standards Publication NU-1 2001 using 3/8" crystal.

Pinhole Collimator	isotope		
	^{99m} Tc	¹²³ I	¹³¹ I
Hole Shape	Round	Round	Round
Number of Holes	1	1	1
Hole Diameter (mm)	4,6,8	4,6,8	4,6,8
Cone length (approx. in mm)	200	200	200
Diameter at Base of Cone (approx. in mm)	300	300	300
Sensitivity @ 10 cm with 4 mm (cpm/μCi)	123	111	67
Sensitivity @ 10 cm with 6 mm (cpm/μCi)	271	243	133
Sensitivity @ 10 cm with 8 mm (cpm/μCi)	478	426	221
Geometric Res. @ 10 cm with 4 mm (mm)	6.2	6.3	7.5
Geometric Res. @ 10 cm with 6 mm (mm)	9.3	9.3	10.6
Geometric Res. @ 10 cm with 8 mm (mm)	12.3	12.4	13.6
System Res. @ 10 cm with 4 mm (mm)	6.6	6.6	7.6
System Res. @ 10 cm with 6 mm (mm)	9.5	9.5	10.7
System Res. @ 10 cm with 8 mm (mm)	12.5	12.5	13.7
Weight in lb.	165	165	165
Weight in kg	74.3	74.3	74.3



Semi-Automatic Collimator Server

BiCore™ Collimators

A wide variety of optional collimators are available for all energies and include ultrahigh energy, fanbeam, and pinhole. The unique collimator exchange combines fully automated collimator installation with rapid insertion. The collimator server supports 2 sets of collimators, providing the operator with the ability to remove and install collimators from the same cart, eliminating one trip to and from the collimator storage area.

Collimator Server (w/o collimators)		
Height	132.1 cm	(4 ft. 4 in.)
Width	110.5 cm	(2 ft. 7.5 in.)
Depth	110.5 cm	(2 ft. 7.5 in.)
Weight	120.2 kg	(265 lb.)

For single-detector systems, the collimator server can hold up to four collimators (or two collimators and a pinhole collimator). All servers enable easy storage, transport, installation and removal of collimators.



e.cam Mobile Environment Package



General Coach Requirements

- Minimum coach size: 8' x 24' (8' x 26' is preferred)
- Air ride suspension
- Self-leveling hydraulic jack system
- 30,000 lb. minimum GVW Rating
- Recommended ceiling height: Minimum of 7 ft.
- Recommended floor construction: Minimum of 1.125" thick oak on 3" steel I-Beams on 12" centers
- 42" access to installation

Patient Handling System



Versatile Design

The e.cam's motorized patient bed supports patient weights up to 180 kg (400 lb), meeting the needs of a wide range of clinical applications. The low attenuation characteristics of the ultra-thin pallets and the close proximity of the detector to the patient optimize study resolution. The patient bed lowers to a convenient 48.3 cm (19 in.) for easy patient access. Both the bed with reconfigurable arm supports, and the optional pallets provide patient comfort during the scan.



Easy Configuration

The patient bed (shown on left with the standard pallet) can be configured with right- or left-side patient access to accommodate site-specific installation requirements. The bed is easily removed for rail-free access to imaging patients on gurneys or wheelchairs. It comes equipped with a head holder, a cardiac arm rest, a built-in patient bed ruler, and a contoured patient pad. Also, the ECG connector and power outlet are located at the base of the patient bed where an external ECG monitor can be connected.



Patient Comfort Accessories

The standard cardiac arm rest provides a comfortable resting area for the patient's elbows when positioned over the head, thus reducing patient movement during acquisition. The included head holder, which mounts to the top of the patient bed pallet's front end, supports the patient's head and reduces head movement during brain scanning. Optional dedicated pallets for pediatric and scintimammography applications are also available.



Patient Bed Features

Specifications

Patient Bed

Width	88.9 cm (35.4 in.)
Length	251.5 cm (99 in.)
Weight	253 kg (562 lb.)
Height	109.2 cm (43 in.)
Vertical Motion Range	48.3-110.5 cm (19.0-43.5 in.)
Maximum Vertical Speed	120 cm/min. (47.2 in./min.)
Pallet Material	Aluminum
Pallet Thickness	2.54 mm (0.10 in.)
Pallet Width SPECT	35.6 cm (14 in.)
Pallet Width Whole Body	64.8 cm (25.5 in.)
Attenuation @ 140 keV	< 7%
Max. Patient Weight	180 kg (400 lb.)
Max. Deflection of Patient Pallet	< 3.2 mm (< 0.125 in.)
Max. Scan Length in Whole Body Mode	202 cm (79.5 in.)
Horizontal Motion Range	164.5 cm (5 ft. 4.75 in.)
Horizontal Motion Accuracy	0.4 mm (0.016 in.)
Maximum Horizontal Speed	240 cm/min. (94.5 in./min.)
Minimum Horizontal Speed	0.1 cm/min. (0.040 in./min.)

Rear Pallet Support

Width	35.6 cm (14 in.)
Length (with bar in)	124.5 cm (49 in.)
Length (with bar out)	153.7 cm (60.5 in.)
Weight	49 kg (109 lb.)

ECG Input

- TTL Signal Input
- 0 to +5 Volt
- Negative and Positive Trigger

ECG Gating

- Forward or Forward/Backward by Thirds Framing in Planar Mode
- Forward or Forward/Backward by Thirds by Percentage Framing in SPECT Mode
- Buffered Beat Window
- Bad Beat Rejection
- Number of Frames per R-R Interval or Milliseconds per Frame
- Automatic or Manual Selection of Beats Acceptance Window
- Integrated ECG Port Conveniently Plugs into Bed, Eliminating Any Cable Obstruction

Integrated Source Holder

At the back of the e.cam gantry is the rear pallet support which is used to support the patient bed pallet as it travels through the gantry. This rear pallet support can be flipped up and out of the way when the patient bed is at its lowest position and detector 1 is at 0° rotation. The rear bed also contains the safety rail, which is used to keep personnel from moving behind the gantry where possible contact could occur with the pallet. A source holder is integrated into this rear bed for detector energy peaking, tuning and other quality control procedures. This source holder was specifically designed to perform intrinsic quality control procedures on both detectors simultaneously.

Mammography Pallet

The specialized mammography pallet design is easily installed on the patient bed and allows for scintimammography acquisitions in both planar and SPECT mode. The patient is in a prone head-in position, and does not need to get off the pallet to change from left to right lateral/oblique views.

Width	35.6 cm (14 in.)
Length	170.2 cm (67 in.)
Weight	4.7 kg (10.5 lb.)
Height	12.7 cm (5 in.)
Pallet Material	Carbon Fiber/Foam/Laminated Wood
Pallet Thickness	2.54/12.7/38.1mm (0.1/0.5/1.5 in.)
Pallet Width SPECT	35.6 cm (14 in.)
Attenuation @ 140 keV	<8.5%
Max. Patient Weight	135 kg (300 lb.)
Max. Deflection of Patient Pallet	<12.7mm (<0.5 in.)

Pediatric Pallet

Designed for use with the e.cam Patient Handling System to image infants in planar or SPECT mode, the pediatric pallet allows patients to be positioned supine, feet first, or head first (for brain scans) and features various restraints to immobilize the knees, elbows and shoulders of young patients during acquisition.

Width	25.4 cm (10 in.)
Length	129.9 cm (51.1 in.)
Weight	6.4 kg (14.16 lb.)
Height	17.1 cm (6.8 in.)
Pallet Material	Carbon Fiber/Laminated Wood
Pallet Thickness	6.35 mm (0.25 in.)
Narrow Portion	3.05 mm (0.12 in.)
Pallet Width SPECT	25.4 cm (10 in.)
Narrow Portion	190.5 mm (7.5 in.)
Attenuation @ 140 keV	<10%
Max. Patient Weight	27 kg (60 lb.)
Max. Deflection of Patient Pallet	<6.35 mm (<0.25 in.)
Horizontal Motion Range	114.3 cm (45 in.)



Profile Attenuation Correction



Clinical Benefits

- Easy to use
- Increased clinical accuracy
- Improved image quality
- Improved diagnostic confidence
- Minimum quality control requirements
- Simultaneous emission and transmission scans

Profile Attenuation Correction

The e.cam Profile attenuation correction system offers improved cardiac SPECT imaging accuracy over an extended range of patient sizes. A unique, multiple-line source array produces a profiled transmission source shape. By varying the activity levels in each of the individual lines, the transmission flux is directed at the center of the patient where it is needed most. The overall activity level of the transmission source is substantially reduced while significantly extending the range of measurable patient sizes up to 180 kg (400 lb.).

To increase throughput, the e.cam system supports simultaneous emission and transmission scatter-corrected SPECT acquisitions using six energy windows for gated and nongated studies. Furthermore, it provides quantitative software that compares the results with a normals database.

When the Profile option is in use, a visual indicator is employed in the field of view on the PPM. The transmission sources can be conveniently retracted against the gantry when the Profile option is not in use.

Cardiac Quantitative Software that Supports Attenuation Correction

- 4D-MSPECT (University of Michigan Medical Center)

Profile Specifications	
Transmission Source Configuration	Multiple Line Array (MLA)
Number of Arrays per System	2
Number of Line Sources per Array	14 (7 pairs)
Transmission Isotope	¹⁵³ Gd
Transmission Energy	100 keV
Transmission Activity (Total)	7.1 GBq (192 mCi) per system
Replenishment Interval	6 months
Replenishment Activity	4 line sources of 740 MBq (20 mCi)
Effective Source Life	3.5 years
Shutter Mechanism (Automatic)	Electric (fail-safe)
Cardiac FOV	53.3 cm x 19.7 cm (W x D) (21 in. x 7.75 in.) (W x D)
Acquisition Matrix	128 x 128 (no zoom)
Sampling Size	4.80 mm/pixel
Acquisition Type	90° SPECT and Gated SPECT
Acquisition Mode	NCO with prescan
Reconstruction Method	Iterative-W Reconstruction
Reconstructed Voxel Size	4.80 mm ³ or 6.20 mm ³
Resolution Recovery	Yes (collimator deblurring)
Supported Emission Isotopes	²⁰¹ Tl and ^{99m} Tc
Supported Collimators	LEHR
Transmission Scatter Correction	Yes, 3-window method
Emission Scatter Correction	No
Supported Patient Weight	up to 180 kg (400 lb.)
QC Interval	1 month (SPECT blank scan)
^{99m} Tc Protocol	Simultaneous Emission/ Transmission
²⁰¹ Tl Protocol	Pseudo-Sequential (single rotation)

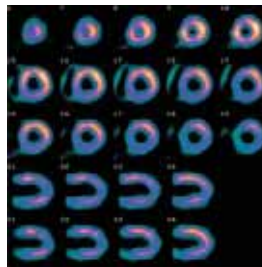

Uncorrected image

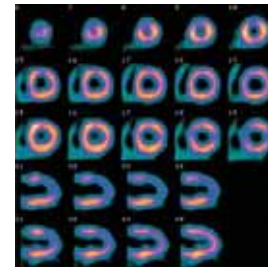

Corrected image

Transmission Flux through Patient Center Profile compared to scanning line source technique

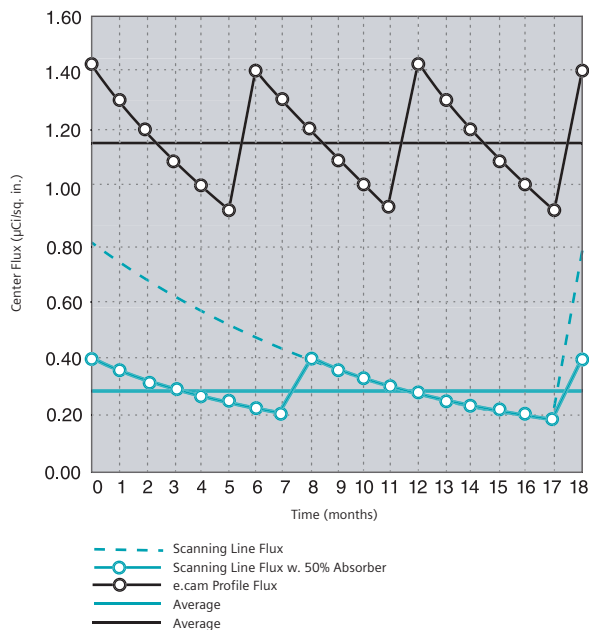

Notes:

- Scanning line flux curves are based on a moving line design with 9.25 GBq (250 mCi) activity using a 50% absorber to reduce the blank scan count rate and extend overall source life to 18 months.
- Profile numbers are based on a multiple line array with seven line pairs and a total of 3.7 GBq (100 mCi) activity.
- Even though the Profile system uses significantly less activity, the flux through the center of the patient (where it matters most) is consistently over four times higher on average.

Coincidence Option

In addition to taking full advantage of the existing advanced features of Siemens HD digital detectors, the e.cam incorporates sophisticated PET-based detector technologies for achieving exceptionally high system performance.

The e.cam+ coincidence option specifically addresses the needs of healthcare institutions seeking to expand the clinical capabilities of their e.cam systems to include FDG imaging capability. This upgrade is easy to use and provides a fully integrated, low cost approach to performing certain studies previously available only on dedicated Positron Emission Tomography (PET) systems. e.cam+ includes two ultrahigh efficiency HD detectors equipped with 5/8-inch (15.9 mm) NaI crystals, special high count rate electronics, and axial shields to reduce scatter and random coincidence events for improved image contrast. The coincidence software includes a fully integrated, easy to use, graphical user interface to provide complete e.cam+ coincidence acquisition and processing functionality.

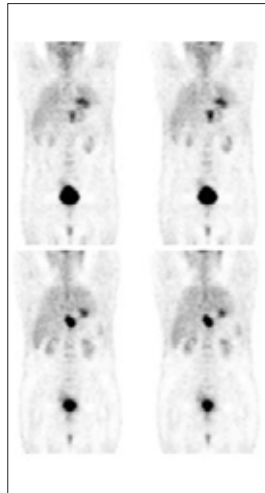

FDG Coincidence

e.cam

Advanced features include:

- PET-based HD detector technologies for superior image contrast and lesion detectability.
- High-count-rate coincidence electronics
- Contrast-enhancing axial shields and on-the-fly Compton pair rejection
- Early event pulse shape discrimination for improved image contrast and better signal-to-noise ratio.
- Continuously variable pulse integration times for optimal energy and spatial resolution.
- Pile-up correction on each individual PMT for improved energy and spatial resolution at high count rates.
- Random events correction for improved image contrast.
- Fully automated peak shift tracking at high count rates for improved signal-to-noise ratio.

Room Layout Examples

System with left side patient access shown in large room.

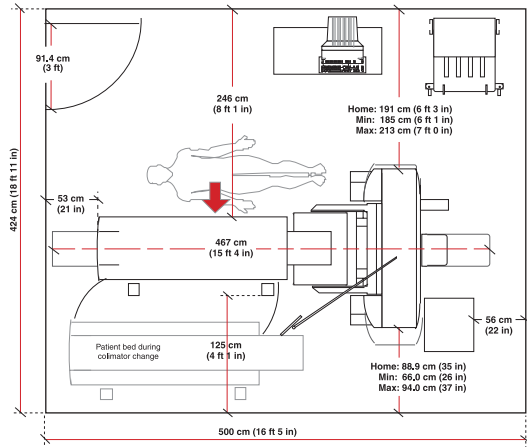

System with right side patient access shown in small room.

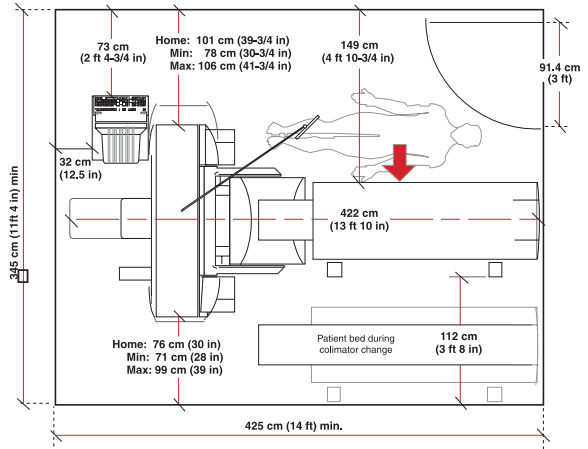

Diagonal configuration

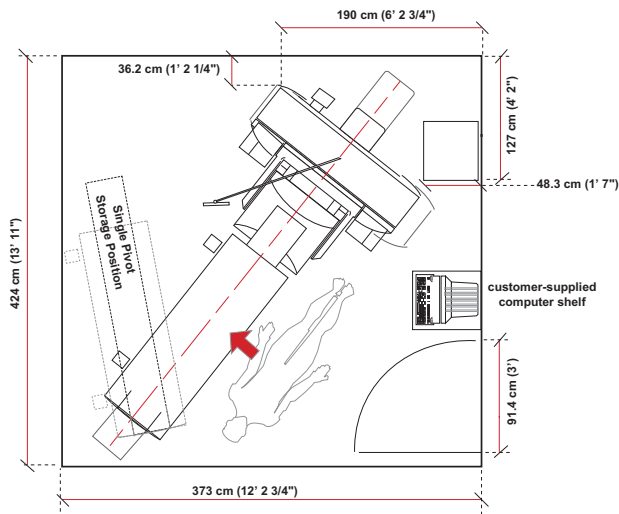

Typical Mobile Installation

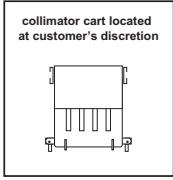
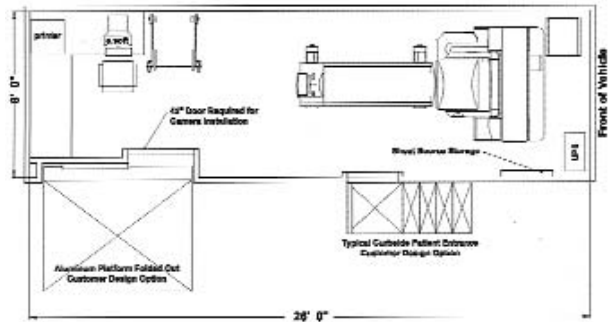

Configurations

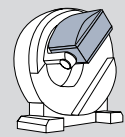

e.media

e.media is an exciting optional patient information and education system that can make an impact in the area of patient comfort, reducing patient movement and associated motion artifacts. e.media can also be used for hospital promotions, patient education, and staff training presentations.

Flash 3D

Flash 3D is Siemens innovative iterative reconstruction algorithm that allows optimization of acquisition time and image time.

Profile Attenuation Correction Option

Profile Attenuation Correction features a unique multiple ¹⁵³Gd line source array that significantly enhances the sensitivity and specificity of myocardial perfusion SPECT by correcting for the nonuniform attenuation from organs surrounding the heart.

e.cam* Coincidence Option

Incorporates many of the technologies developed for dedicated PET. The system features Siemens proprietary HD PET-based detectors, high count rate electronics, axial shields, and coincidence software resulting in superior image contrast and lesion detectability.

Mobile e.cam

The mobile environment package allows installation of a fully-functional e.cam system in a wide variety of trucks and coaches. The technologist-friendly restraints secure the system for travel in minutes.

	Features and Options	e.cam Standard
DETECTORS	Number of Detectors	1
	Detector Orientation	N/A
	3/8" Crystal	Choice
	5/8" Crystal	Choice
	Automatic Body Contouring	Optional
	Caudal/Cephalic Tilt	Optional
GANTRY	Detector Touchpad Sensors	Standard
	HD High-Performance Detector	Standard
	Pass-through Open Gantry Design	Standard
	Patient Positioning Monitor (PPM)	Standard
	e.media Patient Comfort and Education Package	Optional
	Integrated Source Holder	Standard
	Left or Right Side Patient Imaging Bed	Choice
	Ultrathin Pallet with Integrated Arm Support	Standard
	Planar (Static) Acquisition	Standard
	Dynamic Acquisition	Standard
	Whole Body Acquisition	Optional
	Cardiac SPECT Acquisition (76° and 90°)	N/A
	General SPECT Acquisition	Standard
	Whole Body SPECT (Tomographic) Acquisition	Optional
BED	Gated Acquisition	Standard
	Gated SPECT Acquisition	Standard
	Dynamic SPECT (Tomographic) Acquisition	Standard
	Mammography Pallet	Optional
	Pediatric Pallet	Optional
	Cardiac Arm/Head Rest	Standard
	Brain SPECT Head Support	Standard
	ECG Gate/Strip Chart	Optional
	syngo MI Workplace	Standard
	Turbo	Optional
WORKSTATION	A (Acquisition)	Standard
	V (Viewing)	Optional
	P (Processing)	Optional
	AP (Acquisition & Processing)	Optional
	Multimodality Viewing Software	Standard
	User-Defined Workflows	Standard
	Multilingual Interface	Optional
	Flexible Display	Standard
	Cardiac Quantification Software	Optional
	Flash 3D Iterative Reconstruction (Cardiac SPECT)	Optional
	Flash 3D Iterative Reconstruction (General SPECT)	Optional
	3D Display	Optional
	Image Fusion	Optional
	CT Attenuation Correction	Optional
DICOM Worklist	Standard	
DICOM Print	Standard	
Remote Access	Optional	
COLLIMATORS <small>one collimator set must be selected</small>	Low Energy High Sensitivity Collimator	Optional
	Low Energy All-Purpose Collimator	Optional
	Low Energy High Resolution Collimator	Optional
	Low Energy Ultrahigh Resolution	Optional
	Medium Energy Collimator	Optional
	High Energy Collimator	Optional
	Extra High Energy Collimator	Optional
	Fanbeam Collimator	Optional
	Pinhole Collimator	Optional
	Additional Collimator Cart	Optional
OPTIONS	Coincidence Acquisition (5/8" or 1.0" crystal)	N/A
	Profile Nonuniform Attenuation Correction	N/A
	CD Writer	Optional
	Mobile Installation	Optional
	Upgrade to e.cam Variable Angle	N/A
	Single to Dual Detector Upgrade	Optional

ISO 13485 certified, meeting internationally recognized quality standards for good manufacturing practices.

AUTOFORM is a registered trademark of Siemens Medical Solutions USA, Inc.

BiCORE is a trademark of Siemens Medical Solutions USA, Inc.

e.cam is a registered trademark of Siemens Medical Solutions USA, Inc.

syngo is a registered trademark of Siemens AG, Medical Solutions.

Siemens reserves the right to modify the design and specifications contained herein without prior notice. Product performance depends on the choice of system configuration.

Please contact your local Siemens sales representative for the most current information or contact one of the addresses listed below.

© 2006 Siemens Medical Solutions USA, Inc.
All rights reserved.

All photographs © 2006 Siemens Medical Solutions, USA.
All rights reserved.

Note: Original images always lose a certain amount of detail when reproduced.

Siemens Medical Solutions USA, Inc.
Molecular Imaging
2501 N. Barrington Road
Hoffman Estates, IL 60195-5203 USA

Headquarters

Siemens Medical Solutions USA, Inc.
51 Valley Stream Parkway
Malvern, PA 19355-1406 USA
Telephone: +1-888-826-9702
www.usa.siemens.com/medical

Contact Addresses

Siemens Medical Solutions USA, Inc.
Molecular Imaging
2501 N. Barrington Road
Hoffman Estates, IL 60195-5203 USA
Telephone: +1-888-826-9702
www.siemens.com/medical

Siemens Medical Solutions USA, Inc.
Molecular Imaging
810 Innovation Drive
Knoxville, TN 37932-2751 USA
Telephone: +1-888-826-9702

Siemens **Medical**
Solutions that help

©2006, Siemens AG
Order No. A91MI-10055-5C-7600
Printed in USA
PA 0206/3